

Product Code: QLGL

Luckinslive 437540829

Description: Light Gauge BZP Steel Lid

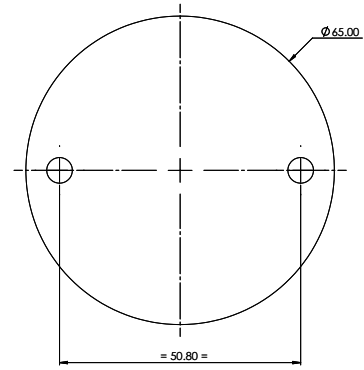
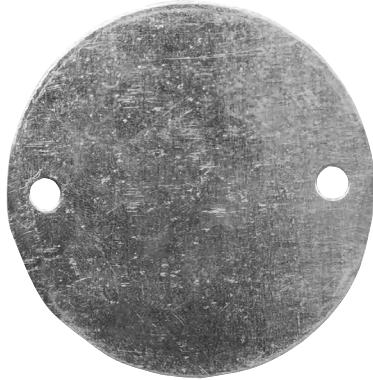

Dimensions

Thickness (mm)	3.2
Diameter (mm)	65
Fixing Diameter (mm)	5

General Information

Finish	Zinc Plated
--------	-------------

Materials

Material: Steel

Standards

BS EN 61386-1:2008

