

Product Code: QIB25G

Luckinslive 437540913

Description: 25mm Galvanised Inspection Bend

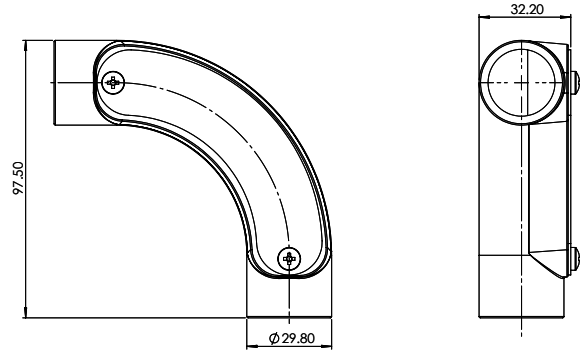

**Dimensions**

|                     |       |
|---------------------|-------|
| Width (mm)          | 100   |
| Height (mm)         | 101   |
| Inner Diameter (mm) | 23.12 |
| Outer Diameter (mm) | 29.79 |
| Thread Size         | M25   |

**General Information**

|              |                 |
|--------------|-----------------|
| Finish       | Galvanised      |
| Conduit Type | Inspection Bend |

**Materials**

|                          |
|--------------------------|
| Material: Malleable Iron |
|--------------------------|

**Standards**

|                    |
|--------------------|
| BS EN 61386-1:2008 |
|--------------------|



CLICK OR SCAN

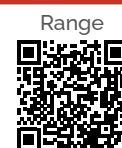

CLICK OR SCAN