

# ESPIRE

Product Code: ES1RF

Description: Alarm RF-Link Module

## Technical Specification Accessories

Luckinslive 437540146

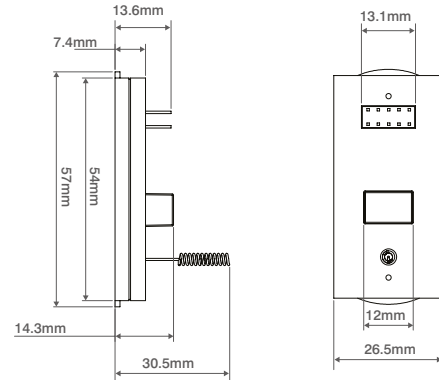

### General Information

Dimensions (mm)	14.3 x 27.5 x 57
Mounting	Recessed into compatible Espire alarm
Weight (Kg)	0.012
Warranty (Years)	5

### Interconnectability

RF-LINK Supported	Built-in
RF-LINK Frequency (MHz)	868.3
RF-LINK Range (Open Field)(m)	100
Maximum Supported Wired & RF-LINK Interconnected Devices	28

### Environment

Operating Temperature (°C)	0 to +40
Relative Humidity Resistance (%)	95 (non-condensing)

**Compatible Products** Espire Alarms: ES1SLV, ES1HLV, ES1MULV, ES1CLV, ES1CHLV

### Features

RF-LINK module for mains powered Espire Alarms

Unit 7 Target Park, Shawbank Road,  
Lakeside, Redditch B98 8YN United Kingdom  
T: +44 (0)1527 515150 | F: +44 (0)1527 515143  
E: info@espuke.com | W: espuke.com



CLICK OR SCAN

Catalogue



DoC



Installation



CLICK OR SCAN